

► Introduction

WPC-W1521A-G is a 15.6-inch all-stainless steel panel PC with IP67/IP69K protection, designed for small workstations and high-performance embedded applications. Powered by an Intel® 12th gen Core™ processor, it offers strong computing power and energy efficiency. With five-wire resistive touch, it operates reliably in wet, oily, or gloved conditions. It supports gigabit Ethernet, wide-voltage DC input, and integrates SafeCore™ system protection, making it a high-performance industrial terminal.

► Features



SUS 304

IP67/IP69K

- SUS304 unibody design withstands acid/alkali wash and high-pressure cleaning, IP67/IP69K rated.
- Powered by 12th Gen Intel® Core™ processors (i7/i5/i3), delivering high performance with low power.
- 15.6inch 16:9 TFT LCD, 1920×1080 (FHD) full-HD display.
- Resistive touch panel supports wet-hand operation with stronger anti-interference for harsh environments.
- LEGO MODE™ modular design, delivering excellent scalability and high maintainability.
- Dual Gigabit Ethernet ports ensure reliable, high-speed industrial network communication.
- Dual-band 2.4G/5G Wi-Fi with Bluetooth enables reliable multi-device wireless connectivity.
- Equipped with 2 x USB and 2 x COM ports for flexible peripheral connectivity.
- Supports wide-range 9–36V DC input for complex industrial power environments.
- Hardware-level auto power recovery ensures automatic restart for unmanned operation scenarios.
- Supports 1× M.2 wireless module for Wi-Fi, Bluetooth, 4G/5G, or USB expansion.
- Supports TPM 2.0 for hardware-based security, ensuring system integrity and trusted operation.
- CESIPC SafeCore™ enhances power-loss resilience, ensuring system recoverability and long-term stability.
- Supports Windows 10/11, CentOS, Ubuntu and other mainstream operating systems.

► Specifications

System Core

CPU / Model	Cores	Threads	Base	Turbo	Cache	TDP	Graphics	Memory / Storage
Intel® Core™ i3-1215U	6 (2P+4E)	8	1.2 GHz	4.4 GHz	10MB	15W	UHD (48 EUs)	DDR5 8–32GB / 1× M.2 NVMe
Intel® Core™ i5-1235U	10 (2P+8E)	12	1.3 GHz	4.4 GHz	12MB	15W	Iris Xe (80 EUs)	DDR5 8–32GB / 1× M.2 NVMe
Intel® Core™ i7-1255U	10 (2P+8E)	12	1.2 GHz	4.7 GHz	12MB	15W	Iris Xe (96 EUs)	DDR5 16–32GB / 1× M.2 NVMe

I/O

DC Input	1 × 4-pin DC input (aviation connector), 9-36V wide-range
USB	2 x USB 2.0 with 2 x Type-A aviation connector
Serial Ports	2 x RS232 (optional RS485/422) with 1 x 10-pin aviation connector
Ethernet Port	2 x 10/100/1000 Mbps ethernet ports with 2 x RJ45 aviation connectors

Wireless Communication

Wi-Fi	Intel N6235, 300Mbps, 802.11a/b/g/n, 2.4G / 5G
Wireless Network	4G LTE module (optional)

Mechanical

Dimension	416.5 (W) × 265(D) × 60.5 (H) mm
Weight	7 KG N.W.
Material	Rugged stainless steel 304 casing
Installation	VESA Mount

LCD & Touch

Touchscreen Type	Resistive 5-wire
LCD Size	15.6inch TFT LCD
Resolution	1920x1080 / 16:9
Brightness (cd/m ²)	300
Contrast Ratio	800:1
Backlight LED Life Time	50,000 hrs (LED Backlight)

Environmental

Protection	Whole IP67 / IP69K level compliant
Operating Temperature	-10°C ~ 60°C (14 ~ 140°F) (extend temperature optional)
Storage Temperature	-20°C ~ 70°C (-4 ~ 158°F)
Relative Humidity	5% ~ 95% RH, support high-humidity environments, non-condensing
EMC	CE, FCC (According to EN 55032 & EN 55035)EN IEC 61000-3-2
Certification	ISO9001:2015; CCC; CE; BIS
ODM	BIOS / Boot on LOGO / OEM
MTBF	MTBF ≥ 60,000 Hours

OS

Windows	Windows 10 / Windows 11
Linux	Ubuntu 16.04 / 18.04 / 20.04 / 22.04

► Dimensions

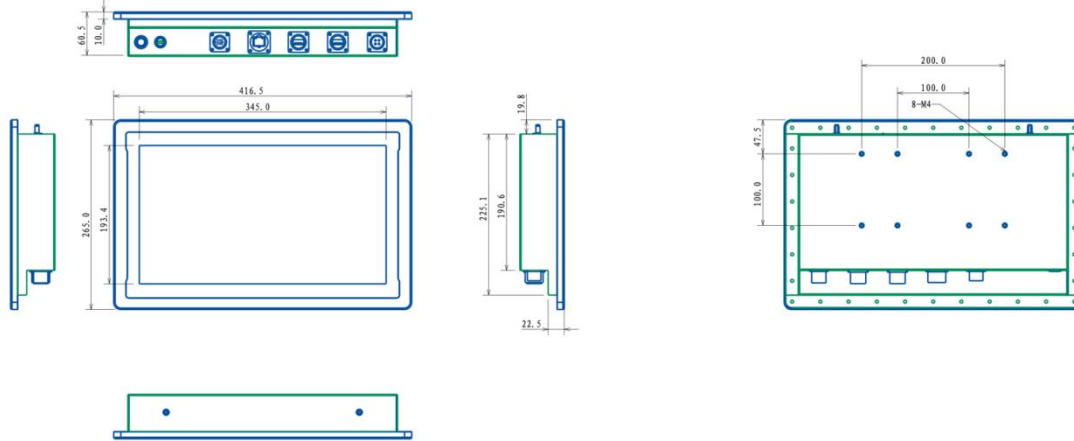

► Product Images



► I/O

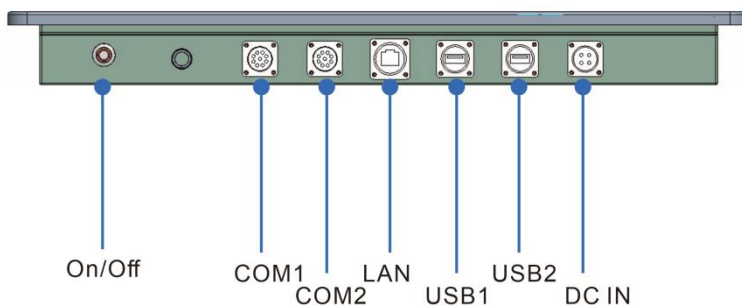

► Applications

Ideal for hygienic processing, food & beverage, pharmaceutical cleanrooms, and washdown environments.



Cleanroom & Test Chamber



Dairy & Beverage Production Line



Biopharmaceutical Cleanroom



Slaughtering & Fresh Processing



Packaging & Vision Inspection



Central Kitchen

► Additional Size Options

G-Series offers multiple screen sizes for various hygiene-grade applications



G-Series 10inch IP69K Panel



G-Series 15inch IP69K Panel



G-Series 21.5inch IP69K Panel

► Accessories



Serial Cable: 10-pin waterproof circular connector to DB9 cable



USB: waterproof circular connector to USB Type-A cable



LAN: waterproof circular connector to LAN RJ45 cable



Power adapter: Waterproof power adapter



Antenna: SMA antenna



► About US

CESIPC (Cloud Embedded Technology Co., Ltd.) was founded in 2009 and is headquartered in Shenzhen. With in-house sheet metal and SMT factories, CESIPC specialize in delivering high-performance, reliable, and customizable industrial computing solutions, including in industrial panel PC, fanless industrial PC, IP67/IP69K panel PC, rugged tablet PC, portable laptop and embedded systems.

Guided by the principles of “Crafting Efficient, Sustainable IPC Solutions”, CESIPC is renowned worldwide for its LEGO-Industrial Computers.

► Contact Us

- Office Phone: +86 755-8528-6060
- Mobile Number: +86 138-2373-2621 (Mr. Fan)
- Procurement Email: wzfan@cesipc.com
- Business Cooperation: sales@cesipc.com
- Postal Code: 518107
- Company Address: 8th Floor, Block 1B, Shangzhi Technology Park, Guangming Avenue, Guangming District, Shenzhen, Guangdong, China