

► Introduction

WPC-S1592A-G is a 15-inch all-stainless steel panel PC with IP67/IP69K protection, designed for small workstations and high-performance embedded applications. Powered by an Intel® 10th gen Core™ processor, it offers strong computing power and energy efficiency. With capacitive touch, it operates reliably with precise touch sensitivity and multi-touch support. It supports gigabit Ethernet, wide-voltage DC input, and integrates SafeCore™ system protection, making it a high-performance industrial terminal.

► Features



SUS 304

IP67/IP69K

- SUS304 unibody design withstands acid/alkali wash and high-pressure cleaning, IP67/IP69K rated.
- Powered by 10th Gen Intel® Core™ processors (i7/i5/i3), offering strong performance with low power.
- 15inch 4:3 TFT LCD, 1024×768 (XGA) resolution.
- P-CAP 10-point projected capacitive touch, fast response and high precision.
- LEGO MODE™ modular design, delivering excellent scalability and high maintainability.
- Dual Gigabit Ethernet ports ensure reliable, high-speed industrial network communication.
- Dual-band 2.4G/5G Wi-Fi with Bluetooth enables reliable multi-device wireless connectivity.
- Equipped with 2 x USB and 2 x COM ports for flexible peripheral connectivity.
- Supports wide-range 9–36V DC input for complex industrial power environments.
- Hardware-level auto power recovery ensures automatic restart for unmanned operation scenarios.
- Supports 1× Mini PCIe module for Wi-Fi, Bluetooth, 4G/5G, or USB expansion.
- Supports TPM 2.0 for hardware-based security, ensuring system integrity and trusted operation.
- CESIPC SafeCore™ enhances power-loss resilience, ensuring system recoverability and long-term stability.
- Supports Windows 10/11, CentOS, Ubuntu and other mainstream operating systems.

► Specifications

System Core

CPU / Model	Cores	Threads	Base	Turbo	Cache	TDP	Graphics	Memory / Storage
Intel® Core™ i3-10110U	2	4	2.1	4.1	4MB	15W	UHD 620	DDR4 4–32GB / 1× mSATA SSD
Intel® Core™ i5-10210U	4	8	1.6	4.2	6MB	15W	UHD 620	DDR4 4–32GB / 1× mSATA SSD
Intel® Core™ i7-10510U	4	8	1.8	4.9	8MB	15W	UHD 620	DDR4 4–32GB / 1× mSATA SSD

I/O

DC Input	1 × 4-pin DC input (aviation connector), 9-36V wide-range
USB	2 x USB 2.0 with 2 x Type-A aviation connector
Serial Ports	2 x RS232 (optional RS485/422) with 1 x 10-pin aviation connector
Ethernet Port	2 x 10/100/1000 Mbps ethernet ports with 2 x RJ45 aviation connectors

Wireless Communication

Wi-Fi	Intel N6235, 300Mbps, 802.11a/b/g/n, 2.4G / 5G
Wireless Network	4G LTE module (optional)

Mechanical

Dimension	386.3 (W) × 310.3(D) × 60.5 (H) mm
Weight	6 KG N.W.
Material	Rugged stainless steel 304 casing
Installation	VESA Mount

LCD & Touch

Touchscreen Type	P-CAP 10-point projected capacitive touch
LCD Size	15inch TFT LCD
Resolution	1024 x 768 / 4:3
Brightness (cd/m ²)	300
Contrast Ratio	1000:1
Backlight LED Life Time	50,000 hrs (LED Backlight)

Environmental

Protection	Whole IP67 / IP69K level compliant
Operating Temperature	-10°C ~ 60°C (14 ~ 140°F) (extend temperature optional)
Storage Temperature	-20°C ~ 70°C (-4 ~ 158°F)
Relative Humidity	5% ~ 95% RH, support high-humidity environments, non-condensing
EMC	CE, FCC (According to EN 55032 & EN 55035)EN IEC 61000-3-2
Certification	ISO9001:2015; CCC; CE; BIS
ODM	BIOS / Boot on LOGO / OEM
MTBF	MTBF ≥ 60,000 Hours

OS

Windows	Windows 10 / Windows 11
Linux	Ubuntu 16.04 / 18.04 / 20.04 / 22.04

► Dimensions

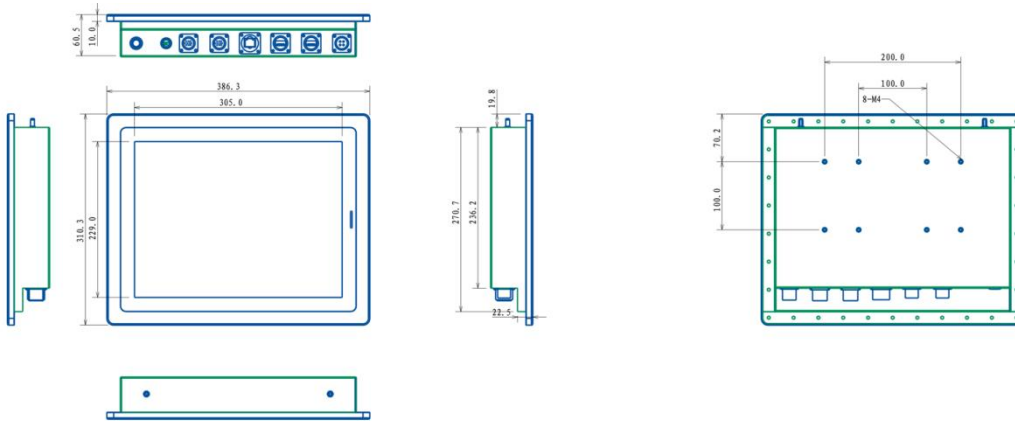

► Product Images



► I/O

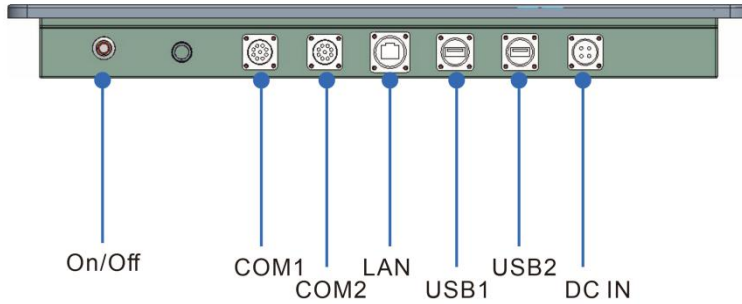

► Applications

Ideal for hygienic processing, food & beverage, pharmaceutical cleanrooms, and washdown environments.



Cleanroom & Test Chamber



Dairy & Beverage Production Line



Biopharmaceutical Cleanroom



Slaughtering & Fresh Processing



Packaging & Vision Inspection



Central Kitchen

► Additional Size Options

G-Series offers multiple screen sizes for various hygiene-grade applications



G-Series 10inch IP69K Panel



G-Series 15.6inch IP69K Panel



G-Series 21.5inch IP69K Panel

► Accessories



Serial Cable: 10-pin waterproof circular connector to DB9 cable



USB: waterproof circular connector to USB Type-A cable



LAN: waterproof circular connector to LAN RJ45 cable



Power adapter: Waterproof power adapter



Antenna: SMA antenna



► About US

CESIPC (Cloud Embedded Technology Co., Ltd.) was founded in 2009 and is headquartered in Shenzhen. With in-house sheet metal and SMT factories, CESIPC specialize in delivering high-performance, reliable, and customizable industrial computing solutions, including in industrial panel PC, fanless industrial PC, IP67/IP69K panel PC, rugged tablet PC, portable laptop and embedded systems.

Guided by the principles of “Crafting Efficient, Sustainable IPC Solutions”, CESIPC is renowned worldwide for its LEGO-Industrial Computers.

► Contact Us

- Office Phone: +86 755-8528-6060
- Mobile Number: +86 138-2373-2621 (Mr. Fan)
- Procurement Email: wzfan@cesipc.com
- Business Cooperation: sales@cesipc.com
- Postal Code: 518107
- Company Address: 8th Floor, Block 1B, Shangzhi Technology Park, Guangming Avenue, Guangming District, Shenzhen, Guangdong, China