

## ► Introduction

WPC-S1091A-G is a 10-inch all-stainless steel panel PC with IP67/IP69K protection, designed for small workstations and high-performance embedded applications. Powered by an Intel® 10th gen Core™ processor, it offers strong computing power and energy efficiency. With five-wire resistive touch, it operates reliably in wet, oily, or gloved conditions. It supports gigabit Ethernet, wide-voltage DC input, and integrates SafeCore™ system protection, making it a high-performance industrial terminal.

## ► Features



SUS 304

IP67/IP69K

- SUS304 unibody design withstands acid/alkali wash and high-pressure cleaning, IP67/IP69K rated.
- Powered by 10th Gen Intel® Core™ processors (i7/i5/i3), offering strong performance with low power.
- 10inch 4:3 TFT LCD, 1024×768 (XGA) resolution.
- Resistive touch panel supports wet-hand operation with stronger anti-interference for harsh environments.
- LEGO MODE™ modular design, delivering excellent scalability and high maintainability.
- Gigabit Ethernet ports ensure reliable, high-speed industrial network communication.
- Dual-band 2.4G/5G Wi-Fi with Bluetooth enables reliable multi-device wireless connectivity.
- Equipped with 2 x USB and 2 x COM ports for flexible peripheral connectivity.
- Supports wide-range 9–36V DC input for complex industrial power environments.
- Hardware-level auto power recovery ensures automatic restart for unmanned operation scenarios.
- Supports 1× Mini PCIe module for Wi-Fi, Bluetooth, 4G/5G, or USB expansion.
- Supports TPM 2.0 for hardware-based security, ensuring system integrity and trusted operation.
- CESIPC SafeCore™ enhances power-loss resilience, ensuring system recoverability and long-term stability.
- Supports Windows 10/11, CentOS, Ubuntu and other mainstream operating systems.

## ► Specifications

### System Core

CPU / Model	Cores	Threads	Base	Turbo	Cache	TDP	Graphics	Memory / Storage
Intel® Core™ i3-10110U	2	4	2.1	4.1	4MB	15W	UHD 620	DDR4 4–32GB / 1× mSATA SSD
Intel® Core™ i5-10210U	4	8	1.6	4.2	6MB	15W	UHD 620	DDR4 4–32GB / 1× mSATA SSD
Intel® Core™ i7-10510U	4	8	1.8	4.9	8MB	15W	UHD 620	DDR4 4–32GB / 1× mSATA SSD

### I/O

DC Input	1 × 4-pin DC input (aviation connector), 9-36V wide-range
USB	2 x USB 2.0 with 2 x Type-A aviation connector
Serial Ports	2 x RS232 (optional RS485/422) with 1 x 10-pin aviation connector
Ethernet Port	1 x 10/100/1000 Mbps ethernet ports with 1 x RJ45 aviation connector

### Wireless Communication

Wi-Fi	Intel N6235, 300Mbps, 802.11a/b/g/n, 2.4G / 5G
Wireless Network	4G LTE module (optional)

### Mechanical

Dimension	278(W)×225.4(D)×57.8(H)mm
Weight	4KG N.W.
Material	Rugged stainless steel 304 casing
Installation	VESA Mount

### LCD & Touch

Touchscreen Type	Resistive 5-wire
LCD Size	10inch TFT LCD
Resolution	1024 x 768 / 4:3
Brightness (cd/m <sup>2</sup> )	300
Contrast Ratio	500:1
Backlight LED Life Time	50,000 hrs (LED Backlight)

### Environmental

Protection	Whole IP67 / IP69K level compliant
Operating Temperature	-10°C ~ 60°C ( 14 ~ 140°F ) (extend temperature optional)
Storage Temperature	-20°C ~ 70°C (-4 ~ 158°F)
Relative Humidity	5% ~ 95% RH, support high-humidity environments, non-condensing
EMC	CE, FCC (According to EN 55032 & EN 55035)EN IEC 61000-3-2
Certification	ISO9001:2015; CCC; CE; BIS
ODM	BIOS / Boot on LOGO / OEM
MTBF	MTBF ≥ 60,000 Hours

### OS

Windows	Windows 10 / Windows 11
Linux	Ubuntu 16.04 / 18.04 / 20.04 / 22.04

## ► Dimensions

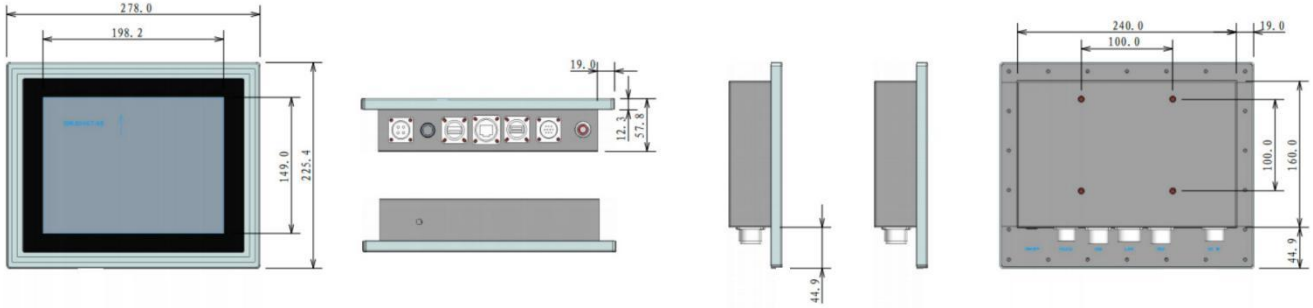

## ► Product Images



## ► I/O



## ► Applications

Ideal for hygienic processing, food & beverage, pharmaceutical cleanrooms, and washdown environments.



Cleanroom & Test Chamber



Dairy & Beverage Production Line



Biopharmaceutical Cleanroom



Slaughtering & Fresh Processing



Packaging & Vision Inspection



Central Kitchen

## ► Additional Size Options

G-Series offers multiple screen sizes for various hygiene-grade applications



G-Series 15inch IP69K Panel



G-Series 15.6inch IP69K Panel



G-Series 21.5inch IP69K Panel

## ► Accessories



Serial Cable: 10-pin waterproof circular connector to DB9 cable



USB: waterproof circular connector to USB Type-A cable



LAN: waterproof circular connector to LAN RJ45 cable



Power adapter: Waterproof power adapter



Antenna: SMA antenna

## ► About US

CESIPC (Cloud Embedded Technology Co., Ltd.) was founded in 2009 and is headquartered in Shenzhen. With in-house sheet metal and SMT factories, CESIPC specialize in delivering high-performance, reliable, and customizable industrial computing solutions, including in industrial panel PC, fanless industrial PC, IP67/IP69K panel PC, rugged tablet PC, portable laptop and embedded systems.

Guided by the principles of "Crafting Efficient, Sustainable IPC Solutions", CESIPC is renowned worldwide for its LEGO-Industrial Computers.



CleanOps Series | 10" Hygienic Panel PC for Washdown

## ► Contact Us

- Office Phone: +86 755-8528-6060
- Mobile Number: +86 138-2373-2621 (Mr. Fan)
- Procurement Email: [wzfan@cesipc.com](mailto:wzfan@cesipc.com)
- Business Cooperation: [sales@cesipc.com](mailto:sales@cesipc.com)
- Postal Code: 518107
- Company Address: 8th Floor, Block 1B, Shangzhi Technology Park, Guangming Avenue, Guangming District, Shenzhen, Guangdong, China